

NC State University Design and Construction Guidelines

Division 00 Planning & Design – Classrooms

1.0 Purpose

A. This section describes the optimal physical design characteristics for 110 classrooms on the NC State University campus. Classroom renovations in existing buildings should be implemented as closely as possible to the intent stated herein.

2.0 Physical Characteristics

A. Classroom Types - The “110” category aggregates classroom facilities as an institution-wide resource, even though they may fall under different levels of organizational control. Thus, a “110 Classroom” is a room used for classes not tied to a specific subject or discipline by equipment in the room or the configuration of the room. NC State University 110 classrooms are defined as one of the following:

1. Seminar Room - General-purpose classroom designed for up to twenty students.
2. Small Classroom - General-purpose classroom designed for a maximum of forty-nine persons inclusive of instructor(s).
3. Large Classroom - General-purpose classroom designed for fifty to ninety-nine persons, inclusive of instructor(s).
4. Lecture Hall - Large classroom designed for one hundred or more students
5. The “110D” category is a 110 classroom that is outfitted for distance education classes that may be broadcast to remote locations, recorded for broadcast at a later time and permit real-time class participation from a variety of locations.

B. Classroom Location

1. Locate 110 classrooms as close as possible to main entrance levels of buildings.
2. Locate large-capacity 110 classrooms or lecture halls near the building entrances.
3. Classrooms on upper floors of buildings should be located as close to the building stairways and elevators as possible.
4. Locate classrooms away from indoor noise-generating equipment and activities, such as toilets and building systems, or away from labs where hazardous materials are used.
5. Locate student study / lounge areas near classrooms.

NC State University Design and Construction Guidelines

Division 00 Planning & Design – Classrooms

6. Locate distance education (DE) 110D classrooms on the interior of a building, preferably with no windows and away from noise generating equipment and activities. If more than one DE classroom is located in a building, cluster them together with a shared AV closet.
 7. Classroom Footprint - The person in the least favored seat should have full visibility to all presented material, i.e. projection screen(s), dry erase marker and/or black boards.
 8. The ideal configuration of seminar, small and large classrooms is nearly square. A rectangle with a length-to-width ratio of no greater than 1.5 to 1 is acceptable.
 9. Each 110D classroom used for distance education requires a media (AV) closet that is 24 sq. ft (min) where programmatically required.
- C. Classroom Support Closet - Provide at least one lockable storage closet for classroom supplies, maintenance and support equipment, in each classroom building. Closet must have corridor access, be located on the same floor as and be as close as possible to the majority of the classrooms. Minimum size shall be 80 square feet.
- D. Classroom Space Requirements
1. Classroom Seating Capacity - The seating capacity for each new or existing classroom may be calculated by subtracting the required square footage of the Instructor Area and dividing the remaining square footage by the required square feet per chair of the type of seating planned for the space. The following rule-of-thumb square feet per chair amounts include circulation areas, and may be used in preliminary planning for a room.
 - a) Movable tablet-arm seats - 20 square feet per chair
 - b) Fixed seats with folding tablet arms - 20 square feet per chair
 - c) Movable tables and chairs - 25 square feet per chair
 - d) Fixed tables and chairs - 25 square feet per chair
 - e) Active Learning - 35 square feet per chair
 - f) Upholstered fixed auditorium seats with folding tablet arms - 20 square feet per chair

NC State University Design and Construction Guidelines

Division 00 Planning & Design – Classrooms

g) Where pedagogical style employs collaborative seating or use of computers, additional space may be required.

2. Instructor Area - The instructor's area should be easily visible from all student seating, and provide instructor seating, writing surface, and electronic controls to all audio/visual and lighting systems in the classroom. The following components and guidelines apply to all small classrooms, large classrooms, and lecture halls.

a) A minimum 8 feet clear space parallel to the instruction wall (10 feet is preferred) shall be provided in small and large classrooms.

b) The instructor's lectern should be located to one side of the centerline of the instruction wall, and may be adjacent to the sidewall. Placement shall not block students' views of the instruction wall nor the projection screen(s). The preferred instructional location/lectern is to the left of the projection screen when facing the teaching wall.

c) A minimum three-foot clearance shall be provided to the front and three feet six inches to the rear of the lectern.

3. Aisles, Spacing, and Clearances

a) Aisles

(1) The minimum aisle width in classrooms is 36".

(2) Side aisles are preferred in lecture halls. The preferred minimum width for lecture hall aisles is 48".

(3) In tiered classrooms and lecture halls, where stepped aisles and ramps are provided, they shall be separated with a half wall or handrail.

b) Spacing and Clearances

(1) The ideal viewing angle is no more than forty-five degrees from either side of the center axis of the teaching surface and from the center axis of each of the projection screen(s). Seating should be placed inside this viewing angle. The projection screen(s) may need to be angled to accommodate ideal viewing angles.

(2) Minimum spacing between rows of movable tablet-arm chairs perpendicular to the teaching wall is 36".

NC State University Design and Construction Guidelines

Division 00 Planning & Design – Classrooms

- (3) Table leg or pedestal spacing shall not interfere with seating.
- (4) Offset rows of seats in rooms with flat or shallow sloped floors, to facilitate an unobstructed view of the instructor area.

E. Room characteristics

1. Floor Design

- a) Seminar Rooms shall have flat floors.
- b) Wood floor construction for risers is not permitted.

2. Doors

- a) Doors should be of solid construction for durability and sound control.
- b) Classroom doors shall have narrow lite vision panels.
- c) The main entry to classrooms should be located at the rear of the classroom.
- d) Doors to lecture halls shall open into alcoves and be located at the rear or sides of the classroom.

3. Wall Construction

- a) Classroom walls shall have a Sound Transmission Class (STC) rating of 50.
- b) Extend non-structural partitions including drywall to the building structure above.
- c) Movable partitions are not recommended in classrooms.

4. Windows

- a) Windows are recommended for all 110 classrooms.
- b) Windows are discouraged for classrooms used for distance education.
- c) Windows should be placed in sidewalls or rear walls and avoided along instructional wall(s).
- d) Windows shall not swing into classroom.

NC State University Design and Construction Guidelines

Division 00 Planning & Design – Classrooms

5. Ceilings

- a) Ceilings should be a light color, with a minimum reflectance value of 80.
- b) Minimum ceiling height shall be 10'-0" AFF for all classrooms. Larger classrooms require proportionally higher ceilings. Rule of thumb for calculating ceiling height AFF:
 - c) $\text{Min. Ceiling Height in feet at screen} = 4' + (\text{Max. View Distance in feet} / 5)$
 - d) In classrooms with sloping or stepped floor systems, the ceiling height should be a minimum of 8'-0" AFF at the highest floor elevation.
- e) 50-60 percent of the area of ceilings shall be acoustical panels.
- f) The ceiling/floor assembly shall have a minimum sound transmission rating (STC) of 50.
- g) The exposed grid acoustical ceiling system shall be 24" x 24" and the acoustical tiles shall have a Noise Reduction Coefficient (NRC) of .75 or better.

6. Acoustics - Walls and ceilings should be designed to evenly distribute sound throughout the classroom. The acoustic design must control the sounds and voices in the room so that they are heard easily and accurately. Classrooms for distance education may have specific requirements. The following rules of thumb should be considered and applied as required in the design of a classroom:

- a) Ambient noise level in classrooms shall not exceed a NC-45 or 35dB. Impact noise levels in classrooms shall be less than 5dB above the ambient level.
- b) Reverberation time (RT) shall be 0.4-0.6 seconds using the RT-60 method.
- c) A flutter echo can occur between parallel hard surfaces and shall be avoided. Shape of room (i.e.: square vs. rectilinear room) is not as significant, however, floor-ceiling and parallel solid walls are more likely to cause problems. Therefore the following strategies shall be considered:
 - (1) Parallel walls of large classrooms and lecture halls may require angling.
 - (2) Variations in ceiling height and profile may be required.

NC State University Design and Construction Guidelines

Division 00 Planning & Design – Classrooms

- (3) Floors may need to be sloped or tiered.
- (4) Use acoustically absorbent ceiling material along sides and rear of large classrooms and lecture halls that result in a reverberation time less than 0.6 sec in an unoccupied classroom.
- (5) A signal to noise ratio (S/N) of +10dB minimum is required (average hearing) +15dB is preferred (accessible for hearing impairment).

F. Interior Finishes - Interior finishes for classrooms should be durable, easy to clean and repairable. Finishes should be selected to avoid visual distraction. Avoid glossy finishes and very busy patterns.

- 1. Wall coverings
 - a) Color selection for a teaching wall with a whiteboard should contrast from adjacent neutral walls.
 - b) Provide acoustical wall panels where required.
- 2. Flooring - A variety of finishes is acceptable in classrooms. Durability, maintenance and life-cycle cost analysis should guide the selection of the appropriate materials.
 - a) Carpet for classrooms should be commercial/institutional grade continuous-filament type, 100% solution dyed, tufted or fusion bonded level loop, anti-static, U.L. Class A.
 - b) Carpet shall have a lifetime warranty against edge raveling and delamination. Seams should not have to be sealed during the installation process. Chair pads shall not be required.
 - c) Carpet Wear: No more than 10% by weight of pile face fiber during the lifetime of the carpet.
 - d) Color and pattern shall be selected to help conceal dirt and stains. Carpet shall have 10 year warranty against fading.
 - e) An aluminum nosing strip mechanically fastened with a reflective strip is required on treads in tiered classrooms.
 - f) Resilient flooring should be commercial/institutional grade, with slight variegations that help conceal dirt and stains.

NC State University Design and Construction Guidelines

Division 00 Planning & Design – Classrooms

- g) Other flooring materials, such as wood, or tile, should receive sealer.
- 3. Wall Base
 - a) Minimum 4” high rubber cove base is typical.
 - b) If wood is chosen for historic renovations, materials matching existing should be chosen.
- 4. Chair Rail
 - a) Classrooms with movable furniture shall receive a simple profile chair rail sufficient to protect walls from contact with sides and backs of tables, chairs, or desks.
 - b) Install chair rail at 25” to 33” above the floor. Verify mounting height and width with furniture specified.
 - c) Chair rail is not required on a teaching wall where it may interfere with mounting height requirements for dry erase marker boards.
- 5. Window Treatments
 - a) Window Treatments shall be provided at all windows, exterior and interior.
 - b) All windows shall receive as a minimum:
 - (1) Manual chain driven or powered roller shades.
 - (2) For powered shades, provide low voltage systems and include low voltage shade interface that can be controlled from lectern.
 - (3) **OR** Match existing exterior facade window coverings
 - (4) All window treatments are required to have a non-reflective matte finish and unless otherwise specified, the color selection should match or blend with the window frame. The shades should be installed so they cover the window opening as completely as possible.
 - (5) Percentages of light diffusion will be determined for each window by evaluating the individual window’s orientation and the intensity of the exposure.

NC State University Design and Construction Guidelines

Division 00 Planning & Design – Classrooms

- c) Blackout shades shall only be installed where appropriate for the teaching needs of the College or department. Blackout shades shall be installed with light-blocking channels or must overlap the window opening to prevent light leakage.

3.0 CLASSROOM FURNISHINGS

A. Instructor Lecterns

1. Standardized lecterns will be used campus-wide, and specified to match the level of technology planned for the specific classroom. The typical lectern serves as both the instructor's desk and a locking cabinet for instructional technology components.
2. Refer to Attachment B for schematic lectern illustrations and minimum requirements.
3. All lecterns shall have front and rear doors, be properly vented, provide for rack mounted AV equipment, security and accessible control panels.
4. An adjustable portion of the desktop shall provide comfortable workspace for standing or sitting position and be ADA compliant.

B. Student Seating & Writing Surfaces

1. Seating types that may be considered include, but are not limited to the following:
 - a) Movable tablet-arm chairs
 - b) Fixed seats with folding or fixed tablet arms
 - c) Movable tables and chairs
 - d) Fixed tables and chairs
 - e) Fixed auditorium seats with folding tablet arms
2. Seating Specifications
 - a) Writing surfaces shall be durable, with a smooth, non-glare surface.
 - b) Auditorium style seats shall have a seat width of 22"-24".
 - c) Seats at table assemblies shall have a minimum seat width of 19".
 - d) Tablet-arms should be large or oversized (212 square inches minimum).

NC State University Design and Construction Guidelines

Division 00 Planning & Design – Classrooms

- e) Tables should be sturdy, 18 - 24” deep units with a flat PVC or wood edge banding. The minimum table width for each student is 30 linear inches. Fixed tables must be anchored solidly to the floor system. Accessible tables shall be designed to permit vertical height adjustment with one hand.
 - f) Upholstered furnishings shall have heavy-duty stain repellent (e.g.: crypton, nanotex finish) fabric that meets or exceeds 100,000 double-rubs, per the Wysenbeck method.
- C. Fixed Equipment - The following items are required in all 110 classrooms:
- 1. Writing Surfaces - Writing surfaces (dry erase marker or chalk boards) shall be provided in all classrooms. Dry erase marker boards are preferred. All boards shall have the following minimum characteristics:
 - a) All boards shall be minimum 48” high.
 - b) Boards shall extend across entire width of wall in instructor area and along sidewalls for student use.
 - c) All boards shall be mounted with the top of the marker or chalk tray at 34” AFF.
 - d) Position board so vertical seam appearance is symmetrical. All seams or joints in board sections (if required) shall have no gap or are to be covered with a low profile spline connection of matching board.
 - e) Board shall be equipped with full-length, rounded end marker/chalk tray with open ends. There shall be no sharp edges or corners on tray.
 - f) Boards may slide vertically or horizontally.
 - g) Board frame shall have minimum 1” map/display rail and tack strip (with ¼” thick cork insert) and map hooks (minimum 4 map hooks) across the full length of the top edge.
 - h) Specific requirements relating to board type
 - i) Dry Erase Marker Boards
 - (1) Dry erase marker boards shall have a low-gloss white or off-white finish, and a minimum 50-year warranty.

NC State University Design and Construction Guidelines

Division 00 Planning & Design – Classrooms

(2) Dry erase marker boards shall be made of a balanced construction consisting of a “P3 ceramic steel” surface composed of porcelain enamel on 28 gauge steel bonded to a minimum ½" thick MDF core with an aluminum back. Bonding material shall be waterproof.

(3) Board shall have heavy-duty aluminum trim, with all necessary mounting hardware for installation provided. Boards shall be mechanically fastened in place and no glue shall be allowed.

j) Chalk Boards

(1) Chalkboards shall have a black surface and have a 50-year warranty against “polishing”.

(2) Provide at least one dry marker board in the classroom.

2. Projection Screens - Each classroom shall be equipped with one or more projection screens positioned to maximize simultaneous use with board while providing optimal viewing angles.

a) Minimum specifications

(1) Screens shall be seamless.

(2) Matte white finish.

(3) Screen gain shall be between 1 and 1.5.

(4) Glass bead or similar screen surface treatments shall not be used.

(5) Screens 8ft wide and larger shall be tab tensioned.

(6) Screen surface should be easily cleanable with soap and water.

NC State University Design and Construction Guidelines

Division 00 Planning & Design – Classrooms

b) Size

- (1) Screen image height should follow the viewing distance formula of $1/6$ the distance from the farthest or least favored viewer.
- (2) The necessary screen height should be taken into consideration when planning ceiling heights.
- (3) Screen aspect width-to-height ratio shall be 16:10.
- (4) See Attachment E for recommended screen size matrix.

c) Mounting location

- (1) Bottom of viewable area shall be no lower than 48" AFF.
- (2) Mount all screens to allow clearance between the screen and dry erase marker/chalk trays.
- (3) A minimum of six linear feet of board shall remain visible in the instructor area when the screen or screens are in use.
- (4) All viewers shall fall within 45 degrees to either side of perpendicular from the center of the screen, forming a 90-degree viewing angle.
- (5) See Attachment B for additional information.

d) Motorized Screens

- (1) All screens eight feet or more in width shall be motorized unless they are to remain open.
- (2) All motorized screens shall be recessed into ceiling
- (3) Low voltage controls shall be provided with all motorized screens. The low voltage control box (if present) shall be located next to the screen motor above the ceiling in an accessible location for integration with the A/V control system.
- (4) Provide a manual low-voltage wall-mounted toggle switch that operates independently from the A/V control system. Locate the switch adjacent to the instructor area and outside of the screen hanging area.

NC State University Design and Construction Guidelines

Division 00 Planning & Design – Classrooms

- (5) Key operated switches are not allowed.
 - (6) Motorized screens should not have trap doors.
3. Flat Panel Displays -
- a) Use Cases
 - (1) Interactive monitors
 - (a) Always located on the instructional wall and mounting location must maintain full ADA accessibility.
 - (2) Confidence monitors
 - (a) Should be located on the wall opposite the instructor's lectern.
 - (3) Smaller classrooms
 - (a) If the appropriately-sized projector screen size falls below 98", a flat panel display can be utilized in its place
 - (4) Active learning classrooms
 - (a) Displays will be located around the room so that any seat has an unobstructed view of at least one monitor regardless of furniture layout.
 - b) Back Boxes
 - (1) All wall-mounted displays shall have a recessed back box capable of including power, telecom, and AV conduit
 - (a) The box must span the width of a single stud bay
 - (b) The box must be able to support a duplex outlet, single gang outlet for telecom (if needed), and up to 1 ¼" conduit for AV
 - (i) Maintain high voltage power and low voltage separation as much as possible.

NC State University Design and Construction Guidelines

Division 00 Planning & Design – Classrooms

(2) Top of the back box shall be located 3.5” below the top edge of the display and centered horizontally on the display

c) Structural

(1) Adequate mounting reinforcement shall be part of the wall infrastructure wherever flat panel monitors are installed.

4.0 MECHANICAL AND ELECTRICAL SYSTEMS

A. Mechanical (HVAC) Systems

1. Air Distribution

a) Mechanical systems supporting classrooms should generate a background noise of no more than NC 20-25 at diffusers.

b) Locate supply air outlets and return air intakes away from lecterns and fixed microphones.

c) There should be no air discharged onto projection screens.

d) The preferred arrangement of supply air outlets is toward the front of the classroom, with return air intakes at the rear of the classroom.

e) The media (AV) closet should also have supply air and proper venting.

f) 110D classrooms and control rooms for distance education require a constant temperature between 65-80 degrees Fahrenheit and relative humidity between 30% and 65%. Mechanical systems in these rooms shall be designed to minimize noise and vibration. Supply diffusers should be distributed around the perimeter of the DE classroom with sound levels no higher than NC-20 at each grill. Return air grills should be located near equipment.

2. Electrical and Instructional Technology Systems Infrastructure - The electrical items enumerated in this document do not include specifics for all equipment that may be included since those requirements will vary according to which equipment is chosen for a given space and in Attachment C, AV Conduit Riser Diagram. Additional infrastructure may be required to meet the functional needs of the classroom (eg: 110 D DELTA classrooms).

a) Provide 120-volt branch circuit power for all classroom instructional technology system components.

NC State University Design and Construction Guidelines

Division 00 Planning & Design – Classrooms

- b) Dedicated power circuit(s) for technology system infrastructure shall be on same phase for each classroom.
 - c) Minimum of two duplex outlets on each wall of the classroom.
 - d) Two quadruplex outlets on a dedicated circuit for the teaching lectern.
 - e) One duplex outlet on its own dedicated circuit at the ceiling-mounted projector on same phase as the teaching lectern.
 - f) Other outlets for ceiling mounted equipment whose cabling comes from above the ceiling and terminates below the ceiling should be cut into the ceiling tile and mounted on the same tile as the equipment.
 - g) Where motorized projection screen(s) are required, provide 120-volt power to an accessible junction box above the ceiling adjacent to the screen(s) and low voltage control interface(s). Connect power to the electric screen(s) via flex conduit. Provide a cut off switch for the screen.
 - h) If motorized shades are specified, provide 120-volt power to an accessible junction box above the ceiling to tie in with the shades and low voltage control interface.
3. Empty Conduits and Junction Boxes
- a) Provide an accessible AV junction box above the ceiling (preferred), in the wall, or in a closet in each classroom. Box shall be sized appropriately for the number of conduits being used.
 - b) Route one empty 1” conduit with pull string from each projector location to the AV box.
 - c) Provide a minimum of two 1 1/4” conduits from the AV box to the lectern.
 - d) Provide junction boxes for program audio speakers just above ceiling at the left and right front corners of the room, or as room design dictates. Route one 3/4” conduit with pull string from the program audio speaker junction boxes and to the AV junction box.
 - e) If room requires voice amplification, provide junction boxes above each location for speakers in the ceiling. Link the junction boxes with a 3/4” conduit with pull string and then to the AV box.

NC State University Design and Construction Guidelines

Division 00 Planning & Design – Classrooms

f) If using motorized projection screen(s), route one 3/4" conduit with pull string from the low voltage control to the AV junction box.

g) If motorized shades are used in the room, route one 3/4" conduit with pull string from the low voltage control interface to the AV junction box.

h) In 110 classrooms provide one 1" conduit from a 2-gang junction box at all camera positions to equipment rack in media (AV) equipment closet or lectern.

i) In 110 classrooms provide one 1" conduit from a 2-gang junction box at all microphone positions to equipment rack in media (AV) equipment closet or lectern.

4. Telecommunication Outlets

a) Provide a minimum of two university standard telecommunication faceplates for the teaching lectern either in a floor box or on the teaching wall at the lectern location.

b) In large classrooms and lecture halls, additional telecommunication outlets may be required at back of room, at accessible student seating areas, or for wireless access points.

c) See Division 27 for the Communications Guidelines

5. Classroom Lighting

a) See Division 26 for Lighting Guidelines.

5.0 INSTRUCTIONAL TECHNOLOGY

A. Overview - Classroom design should accommodate current pedagogies and technologies while at the same time provide the opportunity for new techniques to be incorporated in the future. To help accomplish this goal, all new or renovated classroom facilities at NC State will receive an infrastructure package based on the description provided herein and the AV Conduit Riser Diagram in Attachment C. This infrastructure must be laid out specifically for each space that requires or may require AV technology.

B. The technology included in each classroom will be determined by NC State.

C. General Technology information and specifications can be obtained at classtech.oit.ncsu.edu/technology-standards

NC State University Design and Construction Guidelines

Division 00 Planning & Design – Classrooms

ATTACHMENT A

Classroom Layout Diagram

This diagram illustrates typical spacing, view angles and design issues to be considered.

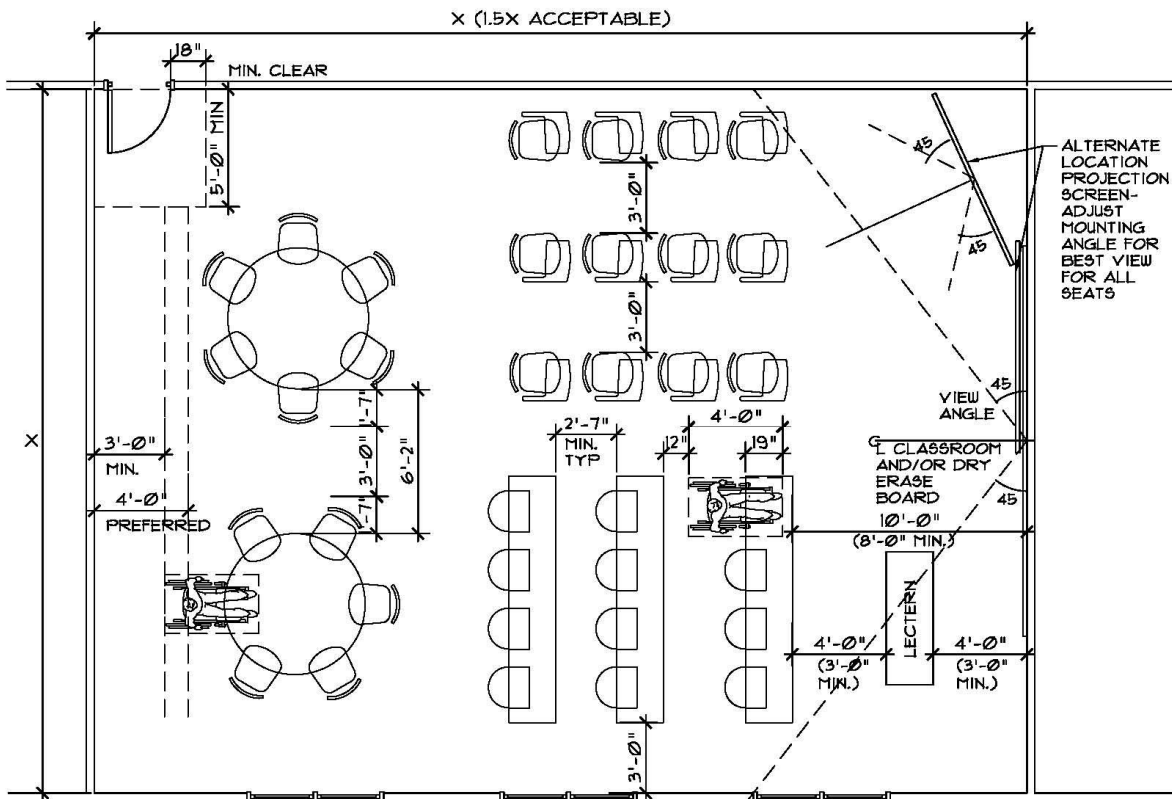

CLASSROOM DIAGRAM

NO SCALE

THIS DRAWING INTENDED TO ILLUSTRATE VARIOUS CLASSROOM REQUIREMENTS, SPACING AND AISLE SIZES ETC. DRAWING FOR REFERENCE ONLY.

DIFFERENT SEATING STYLES SHALL NOT BE MIXED IN CLASSROOMS.

NOTE: AISLE FOR FIXED TABLES MAY BE LOCATED AT THE SIDE OR CENTER OF THE CLASSROOM

COLLABORATIVE/COMPUTER TEACHING METHODS MAY REQUIRE GROUP/FLEXIBLE SEATING ARRANGEMENTS. ADDITIONAL SPACE MAY BE REQUIRED TO ACCODATE CAPACITY AND REQUIRED AISLE SPACING ETC.

VIEW ANGLES FOR ALL DRY ERASE/BLACK BOARDS, PROJECTIONS SCREENS SHOULD BE CONSIDERED WHEN SELECTING SEAT LAYOUT AND SELECTION

TABLET ARM CHAIRS 

FIXED TABLES AND MOVEABLE CHAIRS 

NC State University Design and Construction Guidelines

Division 00 Planning & Design – Classrooms

ATTACHMENT B

Classroom Section

This diagram illustrates typical layout and design issues to be considered.

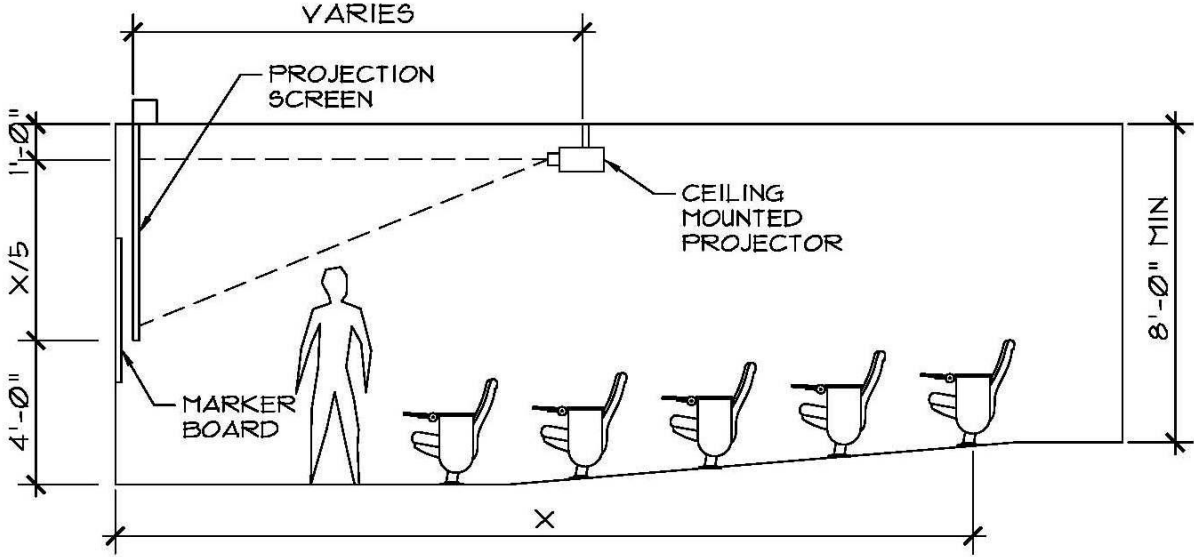

NC State University Design and Construction Guidelines

Division 00 Planning & Design – Classrooms

ATTACHMENT C

Lectern Diagram

This diagram illustrates typical layout and design issues to be considered.

NC State University Design and Construction Guidelines

Division 00 Planning & Design – Classrooms

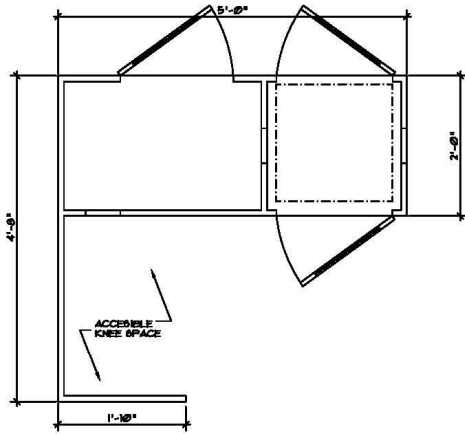

1-RK L-SHAPE LECTERN

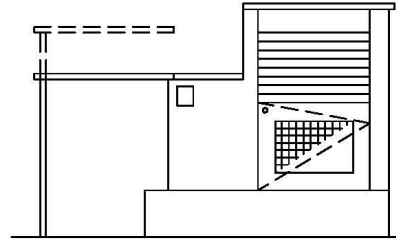

1-RK L-SHAPE SECTION/ELEVATION

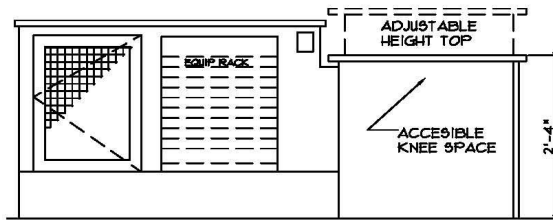

2-RK RECTILINEAR ELEVATION

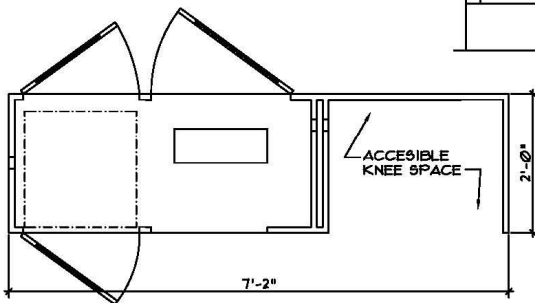

2-RK RECTILINEAR LECTERN

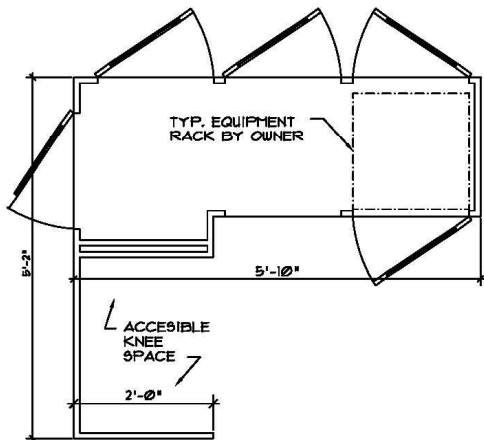

3-RK L-SHAPE LECTERN

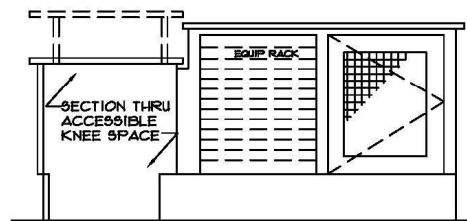

3-RK L-SHAPE SECTION/ELEVATION

ATTACHMENT D

AV Riser Diagrams

NC State University Design and Construction Guidelines

Division 00 Planning & Design – Classrooms

These diagrams illustrates typical AV conduit layout and design issues to be considered.

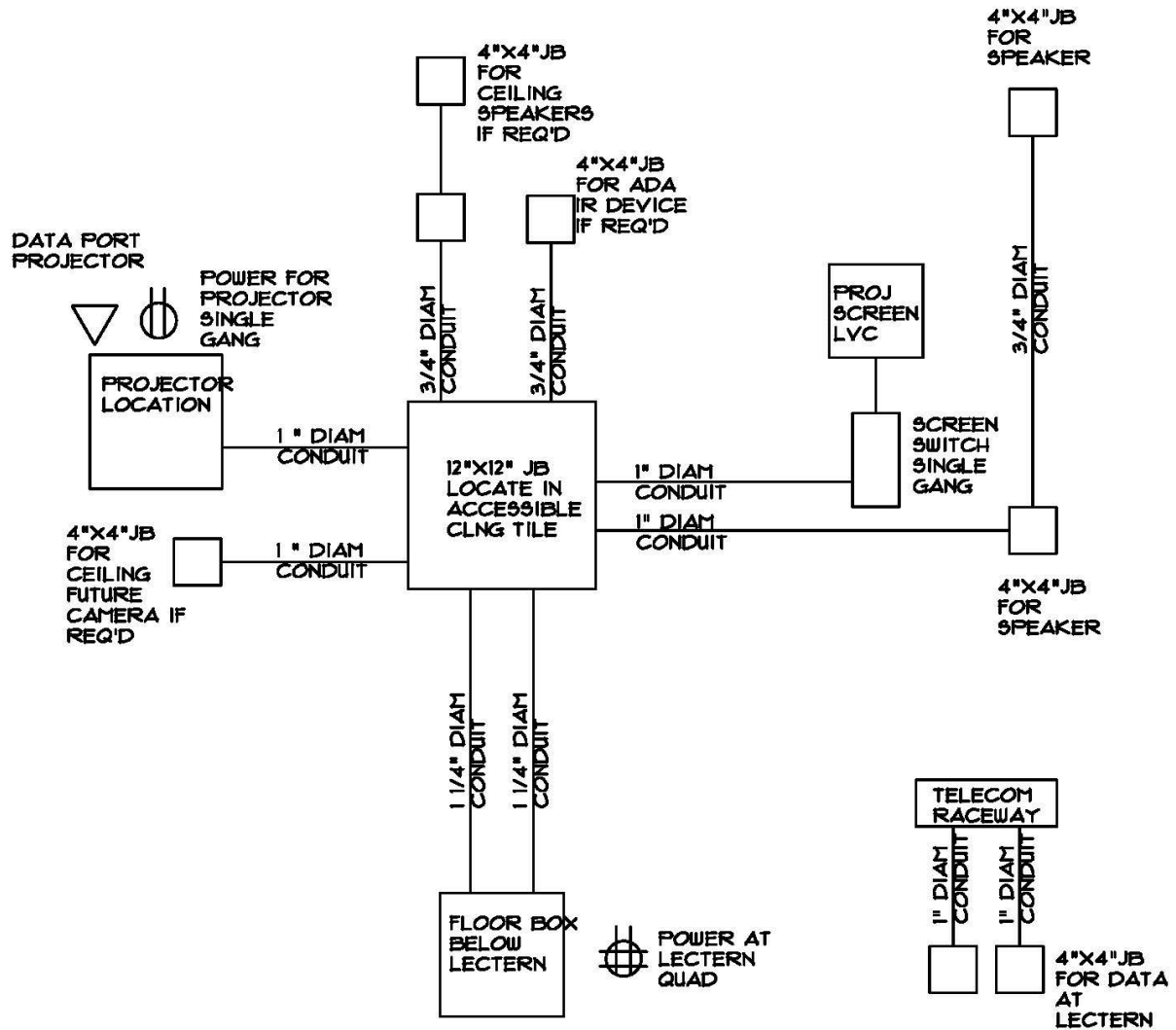

TYP RISER

ATTACHMENT E

Screen Size Matrix

NC State University Design and Construction Guidelines

Division 00 Planning & Design – Classrooms

Least Favored Viewer	Minimum Image Height	16:9 Image Width	Screen Diagonal	Minimum Ceiling Height at Screen	Minimum Distance to Front Row Seat
10'	2'	3.56'	4.08'	6'	4'
15'	3'	5.33'	6.12'	7'	6'
20'	4'	7.11'	8.16'	8'	8'
25'	5'	8.89'	10.20'	9'	10'
30'	6'	10.67'	12.24'	10'	12'
35'	7'	12.44'	14.28'	11'	14'
40'	8'	14.22'	16.32'	12'	16'
45'	9'	16.00'	18.36'	13'	18'
50'	10'	17.78'	20.40'	14'	20'
55'	11'	19.56'	22.44'	15'	22'
60'	12'	21.33'	24.48'	16'	24'
65'	13'	23.11'	26.52'	17'	26'
70'	14'	24.89'	28.56'	18'	28'
75'	15'	26.67'	30.60'	19'	30'
80'	16'	28.44'	32.64'	20'	32'
85'	17'	30.22'	34.68'	21'	34'
90'	18'	32.00'	36.72'	22'	36'
95'	19'	33.78'	38.75'	23'	38'

NC State University Design and Construction Guidelines

Division 00 Planning & Design – Classrooms

GLOSSARY

NC: Noise Criteria - noise levels at in each octave band that is plotted and compared to established NC curve.

NCIH: North Carolina Information Highway

NRC: Measure of absorption or ability of a material to absorb sound

NR: Noise Reduction: % sound that passes through a wall/ceiling to an adjacent room.

RT: The amount of time used to determine sound decay -measured in Sabines using the RT-60 method of calculation. The RT of a space can be described as

- Lively where sound decay is long –e.g. Cathedral/Auditorium.
- Dead where the sound is absorbed quickly – e.g.: recording studio/bedroom.

RT- 60: RT60 the measurement of time it takes a signal to fall -60db. A sample calculator can be found at: www.trinitysoundcompany.com/rt60.html

STC: Sound Transmission Class: Single number that describes the average loss of transmitted sound through a partition/barrier (the higher the number the less transmission of noise).

S/N or SNR: Signal to Noise Ratio: Ratio that describes the intelligibility of the spoken word in a space compared to the ambient sound levels.

Screen Gain: A measurement of the reflectivity of any screen or projection surface. The gain number represents a ratio of the light that is reflected from the screen, when as compared to the light reflected from a standard white (magnesium oxide) board. A screen with a gain of 1.0 will reflect the same amount of light as that from a white board. A screen rated at 1.5 gain will reflect 50% more light as that from a white board, Screen gain measurements are taken from the brightest, generally center perpendicular to the screen. Gain drops off as you move to either side of the center.